

## Installation of NV- m type treatment plant of domestic wastewater

### Installation site preparation

1. Installation of the unit and its performance ensuring systems shall be performed in accordance with technical and/or working project. The designer is responsible for providing calculations, while preparing technical and working projects.
2. The lid should be accessible for constant inspection and for proper functioning of the system.
3. Check diameter of the sewage pipe. Do maintain a gradient that is required in order to ensure wastewater natural flow to the unit.
4. PREPARATION FOR GROUND WORKS: clean a lager site than the treatment plant itself for at least half a metre around it.
5. GROUND WORKS: ground works are carried out by strictly following STR 1.07.02:2005 regulation, technical and/or working project and the general construction norms for installation.

In case, when, while ground digging works are performed, units or communications not indicated in the designed drawings are encountered, works shall be immediately stopped and the person performing technical supervision of construction or the authorised person shall be informed. Works in such an area can be continued only after receipt of the permission.

Finishing ground works to the designed altitude, the foundation shall be check for weak or soaked soil, excavations, etc. Such soil shall be removed to the depth indicated by the person performing technical supervision of construction and shall be filled with a proper soil by compaction. The site shall be prepared to the altitude indicated in the project, soil shall compacted (compaction coefficient shall be from  $0.95 \div 0.98$ , compaction layer shall be 200–300mm).

### Installation of NV-M type treatment plant of domestic wastewater

ATTENTION: unit installation requires for a special attention, as further performance depends on it. Installing the unit it is important to ensure protection of the body of the unit against entering of soil and constructional scrap.

1. Installation of wastewater treatment plant shall be performed following EN 976-2 standard.
2. Treatment plant shall be installed according to the technical and/or working project prepared in advance and harmonized with appropriate institutions.
3. After evaluation of soil properties, an excavation shall follow overhaul dimensions of the plant. Stop digging till 20–30cm to the designed depth of the excavation. Proceed with manual digging that is dig with the spade. This way the unit rests on a fixed soil by its bottom.
4. Before lowering the plant to the excavation, **IT IS NECESSARY TO CHECK**, if the depth of wastewater feeding tube and the height of the treatment plant inflow coupling, and angles of the inflow and outflow tubes of the treatment plant do match.
5. The unit shall be lowered to the excavation by using typical lifting mechanisms. After a careful lowering to the excavation, the unit shall be aligned with the help of the lever.

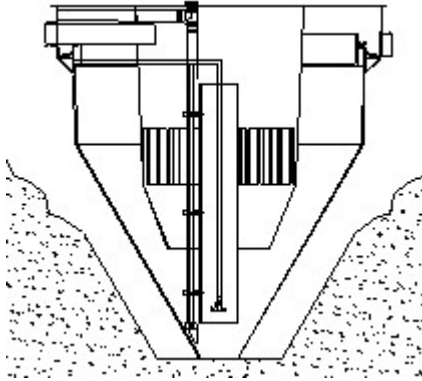

Figure 1

6. For an appropriate performance of the treatment plant it is important for the overflow threshold at the top of it to be horizontal. This is possible by firstly filling the round channel (inner lateral wall is the overflow threshold) at the top with water and by adjusting the position of the whole treatment plant with the help of a level, according to the position of this water surface, in respect of the overflow threshold. Temporary clogging outflow coupling is required for the water not to run-off, when filling the channel.

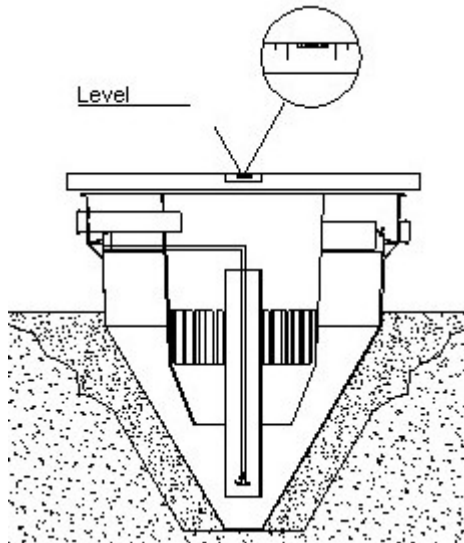

Figure 2

7. Clearance between edges of the excavation and treatment facility are gradually filled with sand earlier delivered to the installation site that is poured by layers of 20–30cm, by thoroughly compacting with the help of mechanisms. **On presence of dry sand, it shall be irrigated during compaction.**
8. During installation (or in case of high level of ground water), **when pouring sand into the excavation around the unit, the same unit shall be gradually filled with water. This is performed as follows: pour 20–30cm of sand into the excavation around the unit and simultaneously pour 20–30cm of water into the unit. Continue further by pouring 20–30cm of ground into the excavation around the unit and simultaneously pouring 20–30cm of water into the unit.**

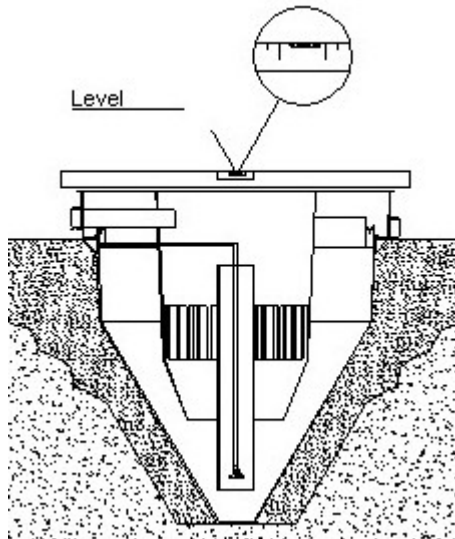

Figure 3

9. Body of the facility shall be poured with sand to the inflow/outflow branch pipes that are then connected with inflow/outflow pipes.
10. After filling the unit with sand to the upper part of the unit, cap it, in order to prevent the poured sand from entering into the inner part of the treatment plant, when continuing filling works.

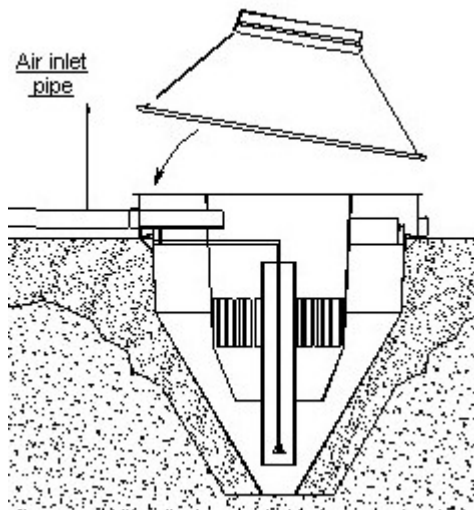

Figure 4

11. Additional upper part of the airlift and branch pipes shall be fitted by connecting one pipe to another. Bag of dewatered sludge shall be hanged. Ring with inspection lid shall be placed. Air feeding pipes shall be attached. Finally, the unit shall be filled with sand to the required height.
12. If unit has been deepened for more than 1.2m, additional rising ring (collected only on necessity) shall be applied. It is pulled without any fastening and sealed by using silicone.
13. Finally all the unit shall be with soil to the designed altitude (recommended: if the unit is installed on the roadway: 50–70mm from the ground surface – if installed on the green lawn in the residential quarter: 200mm – if the unit is installed in an undeveloped territories (STR 2.07.01:2003, Section 450)).
14. Attaching the airblower. Two ends going out the air distribution system shall be connected by air feeding pipes by the end of diffusor or airlift connection.

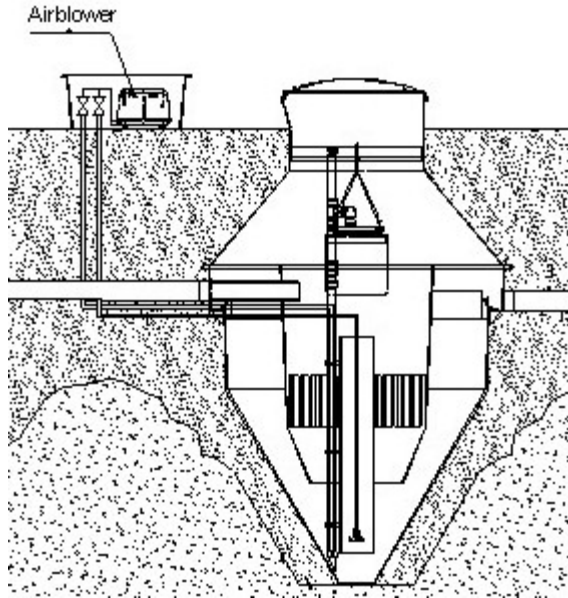

Figure 5

15. In case of high level of ground water, the unit shall be anchored to the foundation of reinforced concrete. Four anchoring options are available (see Fig. 7: a, b). On lowering the anchoring plate, pour about a layer of sand of 10–20 cm thickness and apply a compaction device. Then mount the unit to the anchoring plate.

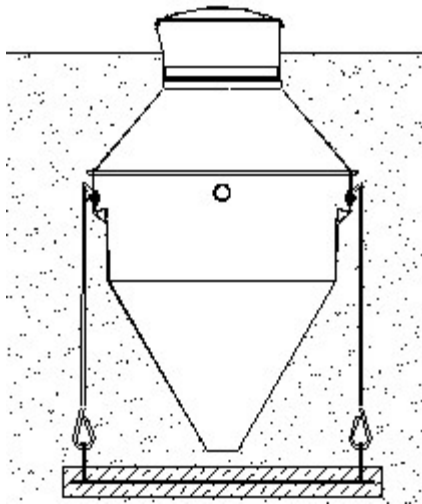

Figure 6

Two holes are bored in the ring of reinforce concrete. One end of stainless steel cable is passed through the bored holes, the other one – through holders of wastewater treatment plant. Both end of the cable are fastened by clamps. Rings of reinforced concrete are laid at a distance from thee unit, in order to form an angle of 20 degrees between the cable and the wastewater plant.

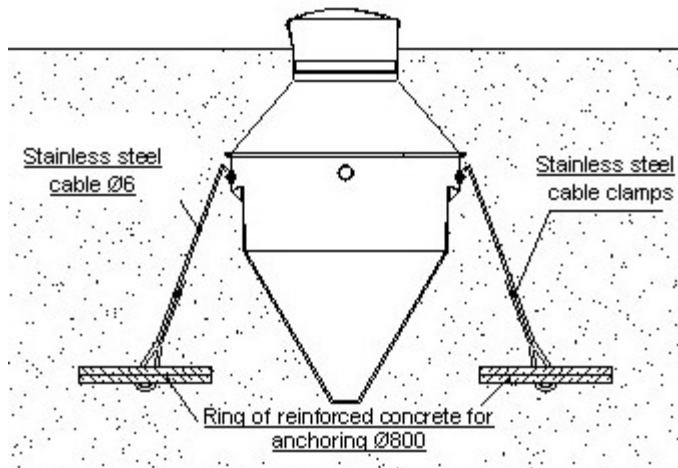

Figure 7

16. When installing the treatment facility under the roadway, a plate of reinforced concrete is fitted (recommended area > 150% of the surface area of the unit), by distributing the transport load off the treatment facilities. While drawing the project, thickness of the plate of the reinforced concrete in every case shall be calculated by evaluating the weight of transport means driving above the facility, transport flow intensity. The designer is responsible for calculations, while preparing technical and working projects.

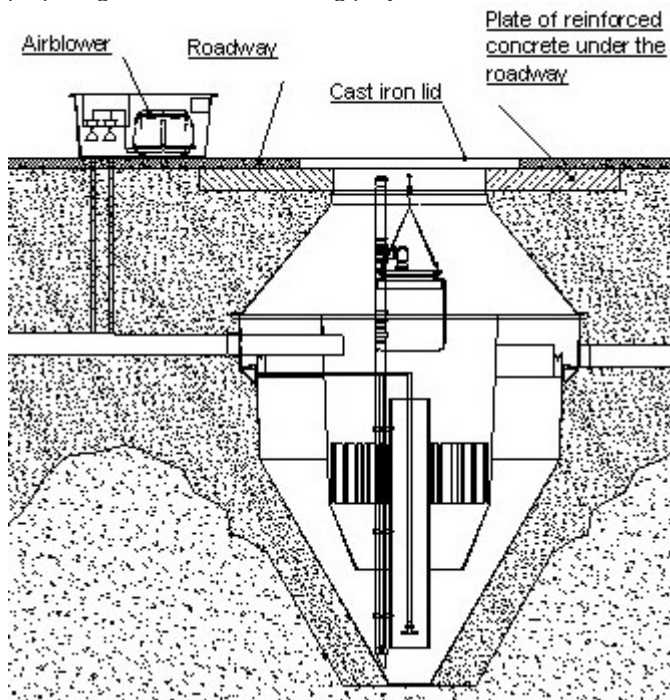

Figure 8

ATTENTION: unit installation requires for a special attention, as further performance depends on it. Installing the unit it is important to ensure protection of the body of the unit against entering of soil and constructional scrap.